

### THERMODYNAMIC STEAM TRAPS DT42/2

#### DESCRIPTION

Thermodynamic DT42/2 disc steam traps are compact and lightweight-easy to install traps, excellent for high pressure systems, including steam tracing applications. These traps have only one moving part and offer a wide operating range, without adjustment. Connections are female screwed or flanged.

#### MAIN FEATURES

Intermittent discharge.  
Operates on superheated steam.  
The seat and disc can be easily replaced in field without removing the trap from the line.  
Unaffected by water hammer and vibrations  
Built-in easy-to-clean strainer.

- OPTIONS:** Insulation cover  
Blowdown valve
- USE:** Saturated and superheated steam.
- AVAILABLE MODELS:** DT 42/2
- SIZES:** DN ½" to DN 1" – DN15 to DN25
- CONNECTIONS:** Female screwed ISO7/1 Rp (BS21)  
Flanged EN1092-1 PN40-PN63 or ANSI
- INSTALLATION:** Horizontal installation recommended.  
Can be installed in any position.
- APPLICATION LIMITS:** Min-working pressure – 0,25 bar  
Max.working back pressure – 80%



( Threaded nickel plated )



( Flanged and SW black painted )

BODY LIMITING CONDITIONS			
FLANGED PN63 *	FLANGED PN40 / ANSI 300 *	FLANGED ANSI 150 **	RELATED TEMP.
ALLOW. PRES.	ALLOW. PRES.	ALLOW. PRES.	
63 bar	40 bar	19,3 bar	50 °C
55,5 bar	35 bar	15,8 bar	150 °C
48 bar	30,4 bar	12,1 bar	250 °C
43,5 bar	27,6 bar	10,2 bar	300 °C

PMO - Max. operating pressure 42 bar

TMO - Max. operating temperature 300 °C

\* Rating according to EN1092-1:2007 \*\* Rating according to EN1759-1:2004

Note: Body limiting conditions PN63 or below, depending on the type of connection adopted. Rating PN63 for thread, SW and BW.

FLOW RATE CAPACITY IN Kgs/h														
MODEL	SIZE DN	DIFFERENTIAL PRESSURE (bar)												
		1	3	5	7	9	12	15	18	21	24	30	35	42
DT 42/2	1/2"-15	180	250	300	380	430	500	550	590	620	690	730	770	820
DT 42/2	3/4"-20	320	450	530	600	690	720	810	850	900	930	950	980	1040
DT 42/2	1"-25	320	450	530	600	690	720	810	850	900	930	950	980	1040

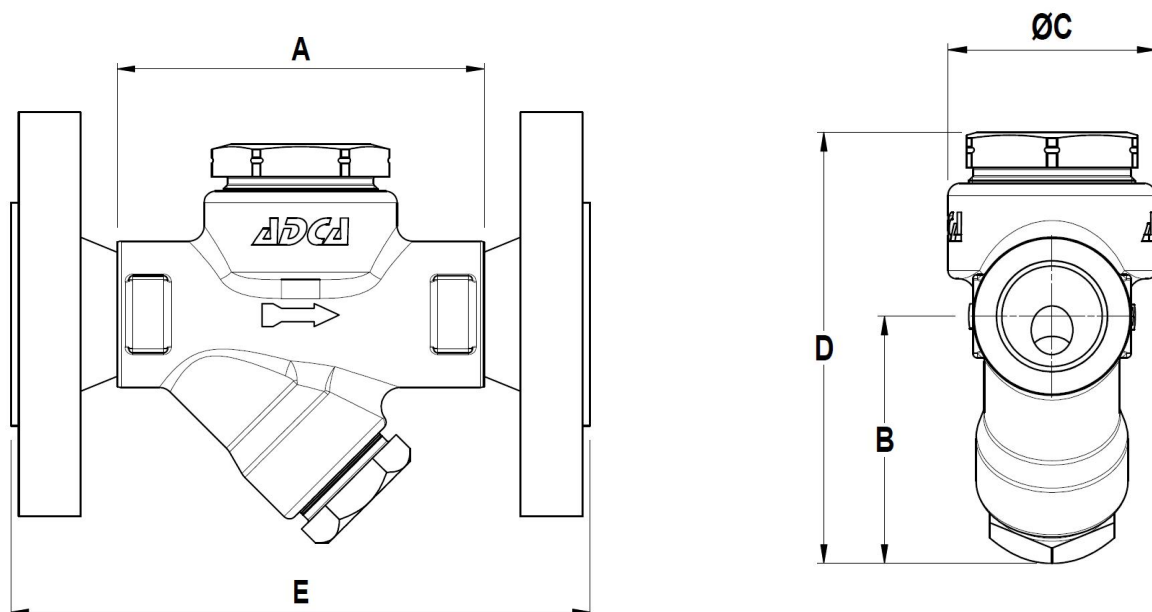

DIMENSIONS (mm)													
Screwed and SW *						EN PN16/PN40		EN PN63		ANSI 150		ANSI 300	
SIZE DN	A	B	C	D	WGT. Kgs	E	WGT. Kgs	E	WGT. Kgs	E	WGT. Kgs	E	WGT. Kgs
15-1/2"	95	60	50	104	1,3	150	2,8	150	3,7	150	2,4	150	2,8
20-3/4"	95	60	50	104	1,2	150	3,3	150	5,2	150	2,8	150	3,6
25-1"	95	66	50	110	1,5	160	4	160	6,5	160	3,6	160	4,5

\* BW (butt weld) on request.

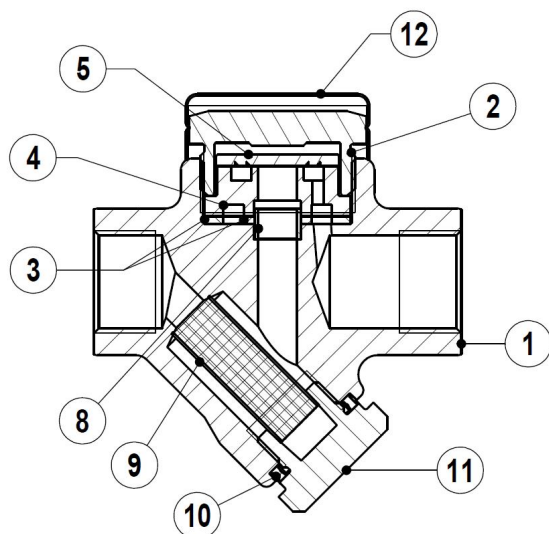

MATERIALS		
POS.Nr.	DESIGNATION	MATERIAL
1	Body	P250GH / 1.0460
2	Cover	AISI 304 / 1.4301 AISI 303 / 1.4305
3	*Gasket	Stainless St./Graphite
4	*Seat	Hardened St.Steel
5	*Valve disc	Hardened St.Steel
8	*Tube	AISI 304 / 1.4301
9	*Strainer screen	AISI 304 / 1.4301
10	*Gasket	Stainless St./Graphite
11	Plug	A105 / 1.0432
12	Insulation cover	AISI 304 / 1.4301

\*Available spare parts.