

PRESSURE REDUCING VALVE RP45 (EN)

DESCRIPTION

The ADCA RP45 series pressure reducing valves are single seat bellows sealed controllers, operating without auxiliary energy, designed for use on steam, compressed air, industrial inert gases and liquids compatible with the construction.

They are particularly suitable for reducing steam pressure in all energy and process systems where pressures should be kept constant.

OPERATION

Pressure reduction is achieved by means of variable throttling of the inlet flow at the valve seat by variation of the flow area between seat and disc. The outlet pressure which is transmitted through the feed-back line to the diaphragm or piston chamber counteracts the spring force acting on the valve spindle and controls the valve aperture corresponding to the spring setting and thus to the required outlet pressure.

MAIN FEATURES

Specially designed high durability bellows, providing pressure balancing and friction less plug stem.

Robust construction (fit-and-forget).

Suitable for use with high pressure turndowns.

Interchangeable actuators

OPTIONS: Soft sealing for steam
Nitrile rubber soft seated version for air and gas applications where tight shut-off is required.
Low-noise flow divider

USE: Steam, compressed air and other gases and liquids compatible with the construction.

AVAILABLE

MODELS: RP45G and RP45GT or N – PN16 SG iron
RP45S and RP45ST or N – PN16 Cast steel
RP45S and RP45ST or N – PN40 Cast steel
RP45I and RP45IT or N – Stainless Steel
(All wetted parts free of ferrous metal or in St.Steel.).

Suffix T : Soft seated with PTFE/GR

Suffix N : soft seated with nitrile rubber

SIZES: DN 15 to DN 150

CONNECTIONS RP45G Flanged EN 1092-2 PN16
RP45S or I Flanged EN 1092-1 PN16 - PN40

INSTALLATION: Horizontal installation.
An “Y” strainer, steam separator and steam trap should be provided upstream the valve.
See IMI, installation and maintenance instructions.



RP45
DN 15 – DN100



RP45
DN 125 – DN150



RP45 I
DN 15 – DN100

CE MARKING (PED - European Directive)

PN 16	PN 40	Category
DN15 to DN50	DN15 to DN32	SEP - art. 3, paragraph3
DN65 to DN150	DN40 to DN100	1 (CE Marked)
/	DN125 to DN150	2 (CE Marked)

LIMITING CONDITIONS

	RP45G RP45S	RP45S	RP45I	RP45GT RP45ST	RP45ST	RP45IT	RP45G N* RP45SN*	RP45SN *	RP45IN *
Body design conditions	PN16	PN40	PN40	PN16	PN40	PN40	PN16	PN40	PN40
Max.upstream pressure	13 bar	25 bar	25 bar	13 bar	25 bar	25 bar	13 bar	25 bar	25 bar
Max.downstream DN15/100	13 bar	18 bar	18 bar	13 bar	18 bar	13 bar	13 bar	18 bar	18 bar
Max.downstream DN125/150	12 bar	16,5 bar	16,5 bar	12 bar	16,5 bar	16,5 bar	12 bar	16,5 bar	16,5 bar
Min.downstream pressure	0,15 bar	0,15 bar	0,15 bar	0,15 bar	0,15 bar	0,15 bar	0,15 bar	0,15 bar	0,15 bar
Max.operating temperature	200°C	250°C	250°C	200 °C	200 °C	200 °C	80 °C	80 °C	80 °C
Max.reducing ratio	25:1	25:1	25:1	25:1	25:1	25:1	10:1	10:1	10:1
Rangeability	10:1	10:1	10:1	10:1	10:1	10:1	10:1	10:1	10:1
Max.cold hydraulic test	24 bar	25 bar	25 bar	24 bar	25 bar	25 bar	24 bar	25 bar	25 bar
Max.hydr. factory valve body test	24 bar	60 bar	60 bar	24 bar	60 bar	60 bar	24 bar	60 bar	60 bar

*Suffix N : - a maximum turndown ratio 10:1 should be observed. Other soft materials on request.

DIMENSIONS (mm)

VALVE				ACTUATOR		
SIZE DN	A	B	WGT. Kgs	TYPE	C	WGT. Kgs
15	130	440	12,7	A1	172	4,3
20	150	440	12,7	A1S	172	4,3
25	160	440	13,7	A10S	172	4,3
32	180	445	15,7	A11	172	4,3
40	200	445	17,7	A12S	172	4,3
50	230	540	25,7	A2	220	7,3
65	290	540	29,7	A21	220	7,3
80	310	610	36,7	A3	282	11,3
100	350	650	53,7	A4	340	16,3
125	400	780	101,4	B1	172	4,4
150	480	790	134,5	B2	220	7,4
				B21	220	7,4
				B3	283	11,6
				B4	340	18,6
				C11S	145	2,3

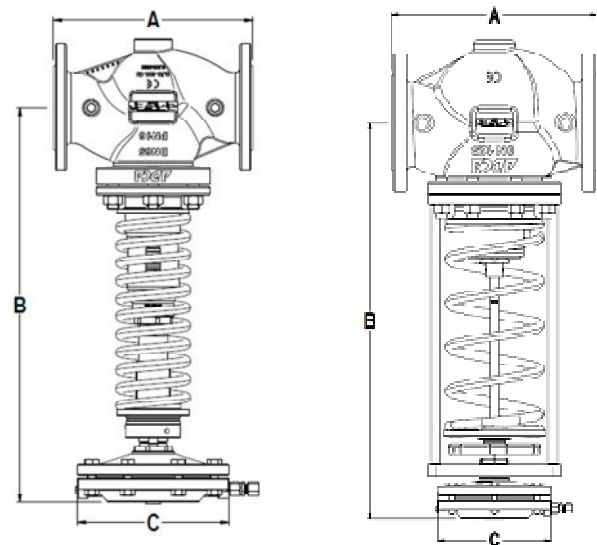

MATERIALS

POS.	DESIGNATION	MATERIAL
1	Valve body RP45G	GJS-400-15 / 0.7040
1	Valve body RP45S	A216WCB / 1.0619
1	Valve body RP45I	CF8M / 1.4408
2	Piston body RP45G and S	GJS-400-15 / 0.7040
2	Piston body RP45I	GJS-400-15 / 0.7040 Nickel plated
3	Valve seat	HARDENED ST.STEEL
4	* Valve disc	HARDENED ST.STEEL
4	* Soft valve disc	AISI304/1.4301 ;NBR (PTFE/GR,etc)
5	Guide	Bronze B62 / ASTM B148-97
6	* Bellows	AISI 316 Ti / 1.4571
7	* Diaph.chamber RP45G	GJL-250 / 0.6025
7	* Diaph.chamber RP45S	A216WCB / 1.0619
7	* Diaph. Chamber RP45I	CF8M / 1.4408
8	* Spindle	AISI 304 / 1.4301
9	* Regulating spring	SPRING STEEL

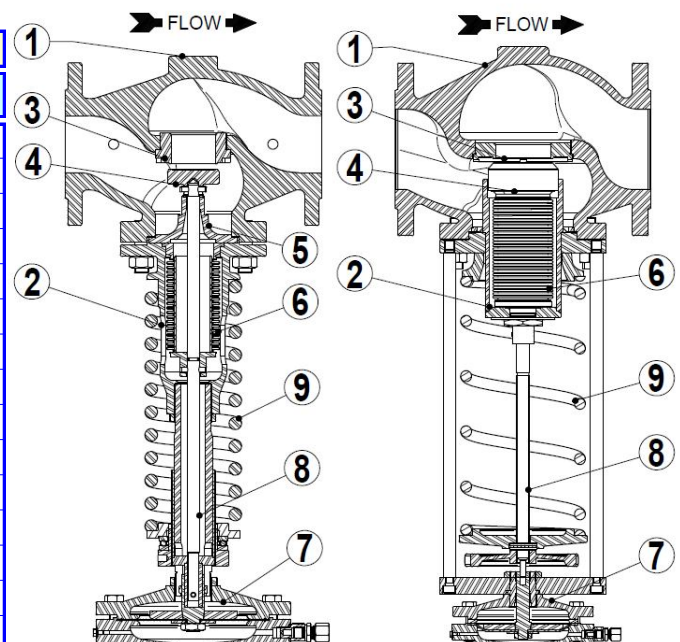

* Available spare parts.



SATURATED STEAM CAPACITY TABLE (Kg/h)
(P2 < 0,58 P1)

INLET barg	VALVE SIZE										
	DN15	DN20	DN25	DN32	DN40	DN50	DN65	DN80	DN100	DN125	DN150
0,5	51	68	90	118	186	300	460	800	1250	1500	1800
0,75	63	84	112	146	230	360	580	1000	1550	1750	2350
1	75	100	133	175	280	430	700	1200	1850	2250	3200
1,5	100	133	175	240	360	590	910	1600	2500	3000	4000
2	126	170	230	290	450	730	1160	2000	3050	3500	4700
2,5	150	200	260	350	550	880	1390	2400	3600	4500	6500
3	175	240	310	400	640	1010	1600	2700	4300	5500	8500
4	220	290	390	510	800	1300	2000	3400	5400	7000	10000
5	260	350	480	620	1000	1600	2500	4200	6500	8000	12000
6	330	440	580	760	1220	1930	3000	5100	8000	9500	14000
7	400	520	700	910	1430	2300	3600	6100	9500	11500	16000
8	450	600	800	1040	1670	2700	4100	7100	11000	13000	18000
9	500	670	880	1180	1800	2900	4600	7800	12000	15000	20000
10	560	750	980	1300	2000	3200	5100	8500	13500	17000	22000
12	680	900	1180	1540	2500	4000	6100	10500	16300	20000	25000
14	800	1050	1400	1850	2900	4700	7200	12600	19000	23000	29000
16	920	1230	1630	2150	3400	5500	8300	14600	22000	26000	33000
18	1040	1400	1860	2450	3800	6200	9500	16600	25000	30000	38000
20	1170	1540	2100	2700	4200	7000	10800	18600	28000	33000	42000
22	1330	1780	2350	3050	4900	7800	12200	21000	32000	36000	45000
24	1500	2000	2600	3400	5400	8700	13700	23500	36000	40000	48000
25	1600	2150	2800	3600	5700	9200	14500	25500	38000	42000	50000

ACTUATOR AND SPRING SELECTION TABLE

DN	Kvs m3/h	ACTUATOR																
			A - 4	A - 4	A - 3	A - 2	A - 21	A - 1	A1S	A - 11	A12S	A-10S	B - 4	B - 3	B - 2	B - 21	B - 1	C-11S
15	4,8	Outlet (bar)	0,15 - 0,49	0,5 - 0,99	1,0 - 1,6	1,7 - 3,8	3,9 - 5,5	5,6 - 8,2	/	8,3-13	10 - 18	/	/	/	/	/	/	/
		Spring N°	66	60	60	60	60	60	/	60	60,1	/	/	/	/	/	/	/
20	6,9	Outlet (bar)	0,15 - 0,49	0,5 - 0,99	1,0 - 1,6	1,7 - 3,8	3,9 - 5,5	5,6 - 8,2	/	8,3-13	10 - 18	/	/	/	/	/	/	/
		Spring N°	66	60	60	60	60	60	/	60	60,1	/	/	/	/	/	/	/
25	9,1	Outlet (bar)	0,15 - 0,49	0,5 - 0,99	1,0 - 1,6	1,7 - 3,8	3,9 - 5,5	5,6 - 8,2	/	8,3-13	10 - 18	/	/	/	/	/	/	/
		Spring N°	66	60	60	60	60	60	/	60	60,1	/	/	/	/	/	/	/
32	11,8	Outlet (bar)	0,15 - 0,49	0,5 - 0,99	1,0 - 1,6	1,7 - 3,8	3,9 - 5,5	5,6 - 8,2	/	8,3-13	10 - 18	/	/	/	/	/	/	/
		Spring N°	66	60	60	60	60	60	/	60	60,1	/	/	/	/	/	/	/
40	14,4	Outlet (bar)	0,15 - 0,49	0,5 - 0,99	1,0 - 1,6	1,7 - 3,8	3,9 - 5,5	5,6 - 8,2	/	8,3-13	10 - 18	/	/	/	/	/	/	/
		Spring N°	66	60	60	60	60	60	/	60	60,1	/	/	/	/	/	/	/
50	26,5	Outlet (bar)	0,15 - 0,49	0,5 - 0,99	1,0 - 1,9	2 - 4,2	4,3 - 6,9	7 - 8,5	/	8,6-13	/	10 - 18	/	/	/	/	/	/
		Spring N°	67	61	61	61	61	64	/	64	/	61	/	/	/	/	/	/
65	51,5	Outlet (bar)	0,15 - 0,49	0,5 - 0,99	1,0 - 1,9	2 - 4,2	4,3 - 6,9	7 - 8,5	/	8,6-13	/	10 - 18	/	/	/	/	/	/
		Spring N°	67	61	61	61	61	64	/	64	/	61	/	/	/	/	/	/
80	79,5	Outlet (bar)	0,15 - 0,45	0,46 - 0,99	1,0 - 1,9	2 - 5	5,1 - 8,9	9 - 13	11 - 18	/	/	/	/	/	/	/	/	/
		Spring N°	68	62	62	62	62	65	62	/	/	/	/	/	/	/	/	/
100	129,5	Outlet (bar)	0,15 - 0,45	0,46 - 0,99	1,0 - 1,9	2 - 6,0	6,1 - 13	/	11 - 18	/	/	/	/	/	/	/	/	/
		Spring N°	69	63	63	63	63	/	63	/	/	/	/	/	/	/	/	/
125	150	Outlet (bar)	/	/	/	/	/	/	/	/	/	0,5-1,5	1,1-2,5	1,5-5,5	4 - 8,5	6 - 12	8 - 16,5	
		Spring N°	/	/	/	/	/	/	/	/	/	/	70	70	70	70	70	
150	204	Outlet (bar)	/	/	/	/	/	/	/	/	/	0,5-1,5	1,1-2,5	1,5-5,5	4 - 8,5	6 - 12	8 - 16,5	
		Spring N°	/	/	/	/	/	/	/	/	/	/	70	70	70	70	70	

Actuator reference without suffix in cast iron, suffix S in cast steel, suffix SS in stain.steel.

Correction factors:

The given capacities apply to the pressure reducing valves at **critical pressure drop** (downstream pressure in barg about 58% of the upstream pressure barg or lower). In case of **non-critical pressure drop** a correction factor must be used as follows:

No correction factor should be used for smaller pressure ratios than 0.7.

PRESSURE RATIO * P2 / P1	CORRECTION FACTOR <i>f</i>
≥ 0,7	1,25
≥ 0,8	1,6
≥ 0,9	2,25

* Pressure ratio in bar abs (barg + 1)

Superheated steam:

If superheated steam is to be reduced instead of saturated steam a correction factor has to be applied as well, the required mass flow must be multiplied by the following factor:

$\frac{V_h}{V_s}$, where V_h = specific volume of superheated steam and V_s = specific volume of saturated steam .

HOW TO SIZE (using table for steam)

Example (valve selection) : Saturated steam capacity: 300Kg/h; Upstream pressure: 3 bar; Downstream pressure required: 2bar.

Solution: First determine correction factor for pressure ratio: $\frac{2+1}{3+1} = 0.75 \rightarrow f = 1.25$,

Then multiply the given capacity: $300 \times 1.25 = 375 \text{ Kg/h}$

Go to 3 bar in the column "bar" of the capacity table. By following the horizontal line you can find out the values for selection of pressure reducing valve. Looking for an equal or higher value than 375 Kg/h. In this case it will be 400 Kg/h. Now, go to the top of the table and read off the nominal size: DN32

On the actuator and spring selection table, for downstream pressure of 2 bar we may see that the recommended actuator is type A-2, considering the valve supplied with spring Nr.60.

How to order: RP45G DN32 PN16 valve complete with spring Nr.60, type A-2 actuator, condensate vessel and copper tube impulse line.

HOW TO SIZE (using Kvs): please consult formulas on IS PV10.00 E or consult factory.

INSTALLATION RECOMMENDATIONS

RP45 is designed primarily for steam, compressed air and non inflammable gases. It has limited use for neutral liquids since the plug close in the same direction of the fluid flow, which can produce vibrations and water hammer when used at less than 20% of capacity. To avoid this, valve can be installed with the fluid direction against the plug under certain conditions. Please consult the factory.

At service conditions where the temperature is more than 100°C it is necessary to protect the diaphragm against overheating by using a seal pot.

Never size the valve according to the pipe diameter in which it has to be fitted but according to the required actual flow .Pipe sizing must also respect the maximum recommended flow velocities according to the medium.

INSTALLATION

Service conditions less than 100°C: with gases the valve is ready to work. In case of liquids the actuator must be filled completely with liquid, so, the vent screw (12) should be open till the water flow without bubbles.

The valve can be installed with the diaphragm pointing upwards or downwards.

Service conditions more than 100°C: Fill the seal pot (11) using a funnel (14) until the water emerges from the actuator vent (12) without bubbles .Close the actuator vent screw (12) and proceed filling the pot until the water reaches the top and close it with the plug. The valve is now ready to work.

The valve must be installed with the diaphragm pointing downwards.

Downstream pressure should be adjusted with the key (13). Compressing the spring, spring force increase and downstream pressure increase. Relaxing the spring, spring force decrease and downstream pressure decrease.

The valve closes when the downstream pressure rises.

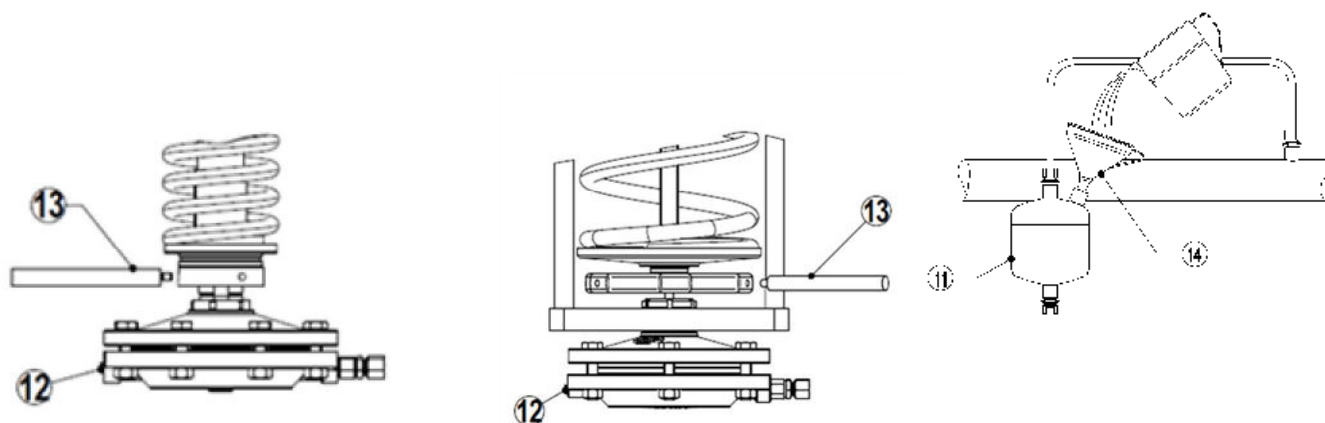

DN 125 – DN 150

DN 15 – DN100

Typical Installation

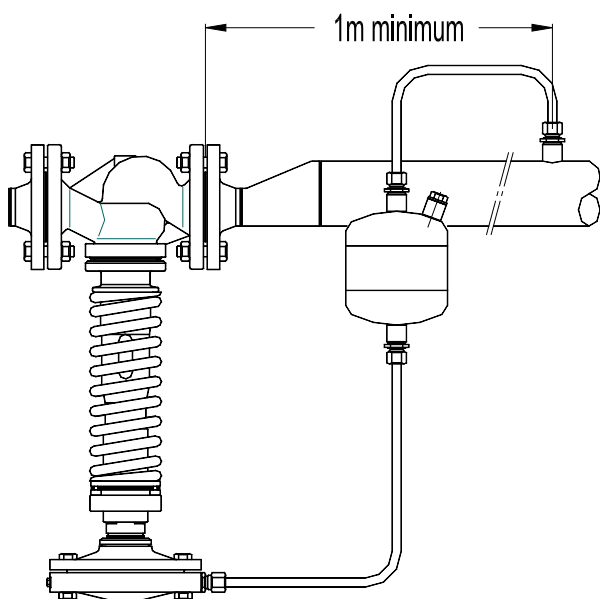
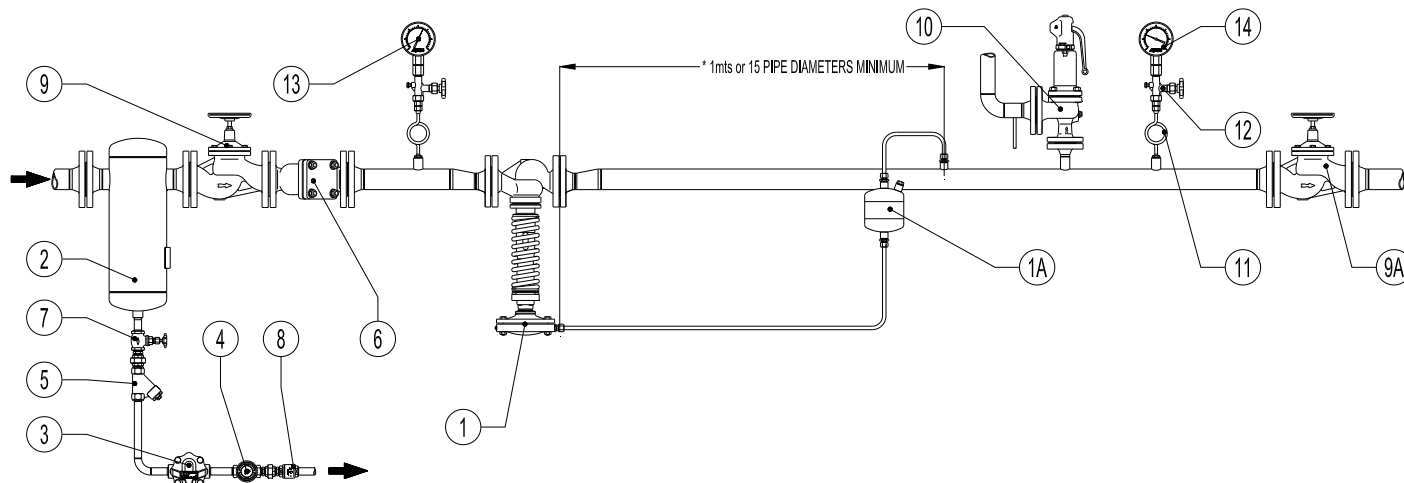

MATERIALS		
POS.	DESIGNATION	MODEL
1	Pressure reducing valve	ADCA RP45
* 1A	Water seal pot	POT
2	Humidity separator	ADCA S 25
3	Steam trap	ADCA FLT series
4	Sight glass	ADCA SW 12
5	Y Strainer	ADCA IS 140
6	Y Strainer	ADCA IS16F
7	Stop valve	ADCA GV32B
8	Check valve	ADCA RT
9	Stop valve	ADCA VF20
9A	Stop valve	ADCA VF20
10	Safety valve	-
11	Coil	ADCA GSC-40
12	Gauge cock	ADCA GC-400
13	Upsteam pressure gauge	ADCA MAN-100
14	Downstream pressure gauge	ADCA MAN-100

* Not necessary when in operation with low temperature compressed air or water.

POT detailed information: see IS POT.10 E 07.13

Remarks:

By-pass: if overpressure can not be accepted the use of by-pass is not recommended. In alternative, for critical process, two pressure reducing stations should be installed in parallel.

PN ratings and materials according to the operating pressures.

* The balance pipe connection is recommended to enter downstream pipe at a minimum of 1 meter from valve. Installation instructions are available (IMI-RP45) and typical assembling drawing.

Special assembling designs may be produced on request.